



Best ALL IN ONE fire extinguisher.
EN3 certified.
Safe to use on any type of fire.
The only fire extinguisher you will ever need.

The Zenova FX6L, is a fire extinguisher range that is effective and safe to use on all types of fires, taking the guesswork out of tackling fires. No more confusion on which extinguisher to use for different fire classes – use the Zenova FX6L for any type of fire.

- ✓ Can put out A, B, C, D, Electrical & F fires.
- ✓ EN3-7 certified for A, B, Electrical & F fires, with BS Kitemark.
- ✓ MED and MER certified

Zenova FX6L extinguishers are fully compliant with PFOA, PFOS and PFAS EU standards and regulations and are compliant with the ECHA Proposed Annex XV Restriction v2.0 to REACH - trace PFAS elements are well below the current standards and below the proposed new standards.

TESTED							
CERTIFIED							
	34A	113B			Safe for use on live electrical equipment up to 1000V	75F	

Features

- ✓ Easy operation,
- ✓ Fast and effective extinguishing.
- ✓ Economical maintenance and service
- ✓ Cut-off valve behind the pressure gauge makes control of the extinguisher easier

Quality and safety

Manufactured for all EU market requirements based on certified ISO 9001 quality system. Fulfils European Standard EN3 and Safety Directive PED 2014/68/UE.

Inspection should be made every 12 months at least. Use only spare parts in accordance with approved sample of fire extinguisher.

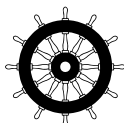



Technical Data

Weight of extinguishing agent	6.0 kg
Extinguishing agent	6 litre Zenova FX fluid
Cylinder test pressure	27 bar
Propellant:	Nitrogen
Operation pressure	15 bar at 20°C
Operating temperature	+5°C / +50°C
Total weight	9.3 kg
Total height	502 mm
Cylinder diameter	160 mm

- Steel tank
- Polyethylene internal lining
- Corrosion-resistant finish
- Plastic base skirt for protection

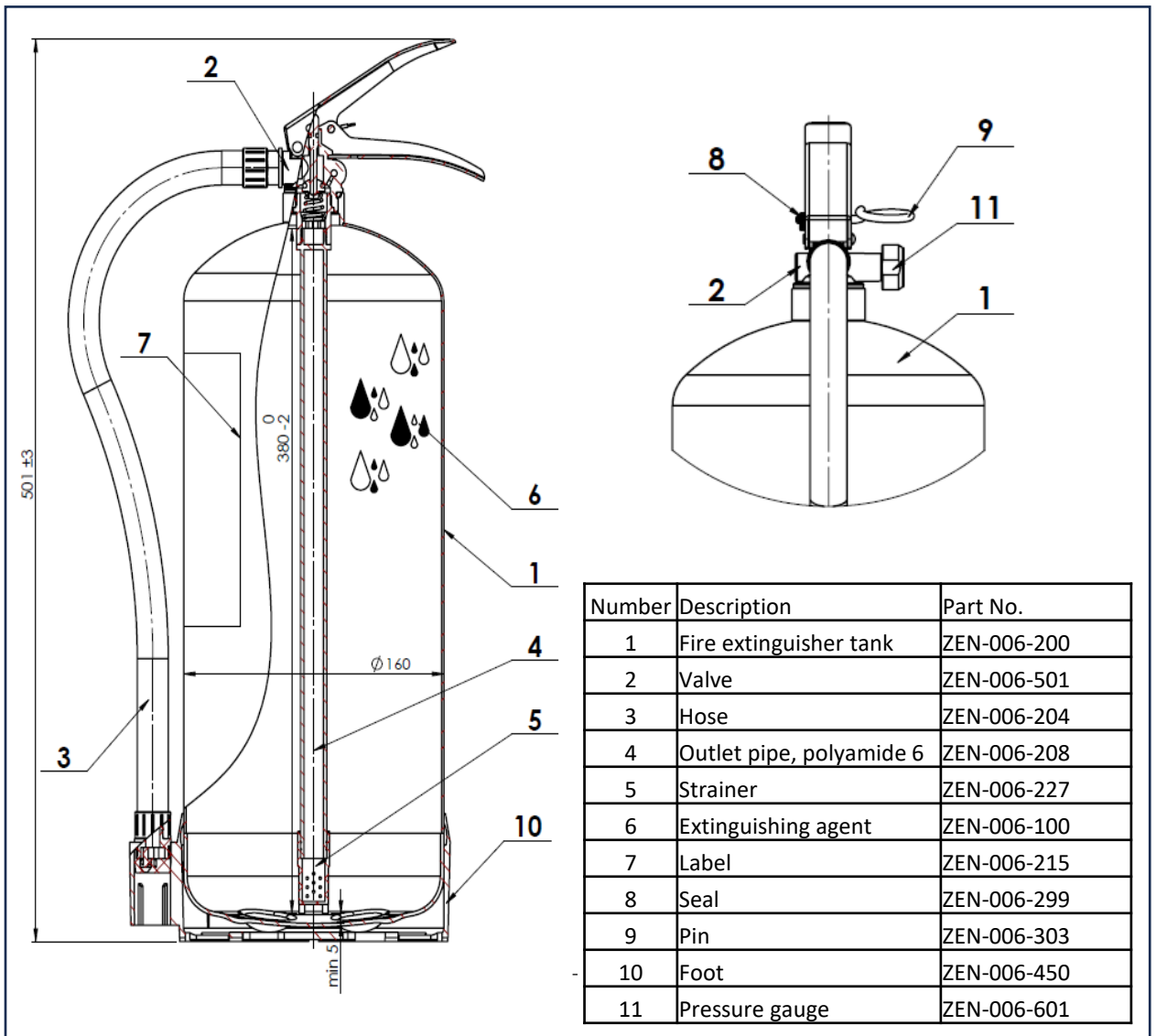

Number	Description	Part No.
1	Fire extinguisher tank	ZEN-006-200
2	Valve	ZEN-006-501
3	Hose	ZEN-006-204
4	Outlet pipe, polyamide 6	ZEN-006-208
5	Strainer	ZEN-006-227
6	Extinguishing agent	ZEN-006-100
7	Label	ZEN-006-215
8	Seal	ZEN-006-299
9	Pin	ZEN-006-303
10	Foot	ZEN-006-450
11	Pressure gauge	ZEN-006-601



**Best ALL IN ONE fire extinguisher.
EN3 certified.
Safe to use on any type of fire.
The only fire extinguisher you will ever need.**

The Zenova FX9L, is a fire extinguisher range that is effective and safe to use on all types of fires, taking the guesswork out of tackling fires. No more confusion on which extinguisher to use for different fire classes – use the Zenova FX9L for any type of fire.

- ✓ Can put out A, B, C, D, Electrical & F fires.
- ✓ EN3-7 certified for A, B, Electrical & F fires, with BS Kitemark.
- ✓ MED and MER certified

Zenova FX9L extinguishers are fully compliant with PFOA, PFOS and PFAS EU standards and regulations and are compliant with the ECHA Proposed Annex XV Restriction v2.0 to REACH - trace PFAS elements are well below the current standards and below the proposed new standards.

TESTED							
CERTIFIED							
	43A	183B			Safe for use on live electrical equipment up to 1000V	75F	

Features

- ✓ Easy operation,
- ✓ Fast and effective extinguishing.
- ✓ Economical maintenance and service
- ✓ Cut-off valve behind the pressure gauge makes control of the extinguisher easier

Quality and safety

Manufactured for all EU market requirements based on certified ISO 9001 quality system. Fulfils European Standard EN3 and Safety Directive PED 2014/68/UE.

Inspection should be made every 12 months at least. Use only spare parts in accordance with approved sample of fire extinguisher.

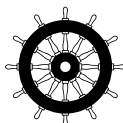



Technical Data

Weight of extinguishing agent	9.0 kg
Extinguishing agent	9 litre Zenova FX fluid
Cylinder test pressure	27 bar
Propellant:	Nitrogen
Operation pressure	15 bar at 20°C
Operating temperature	+5°C / +50°C
Total weight	13.8 kg
Total height	576 mm
Cylinder diameter	185 mm

- Steel tank
- Polyethylene internal lining
- Corrosion-resistant finish
- Plastic base skirt for protection

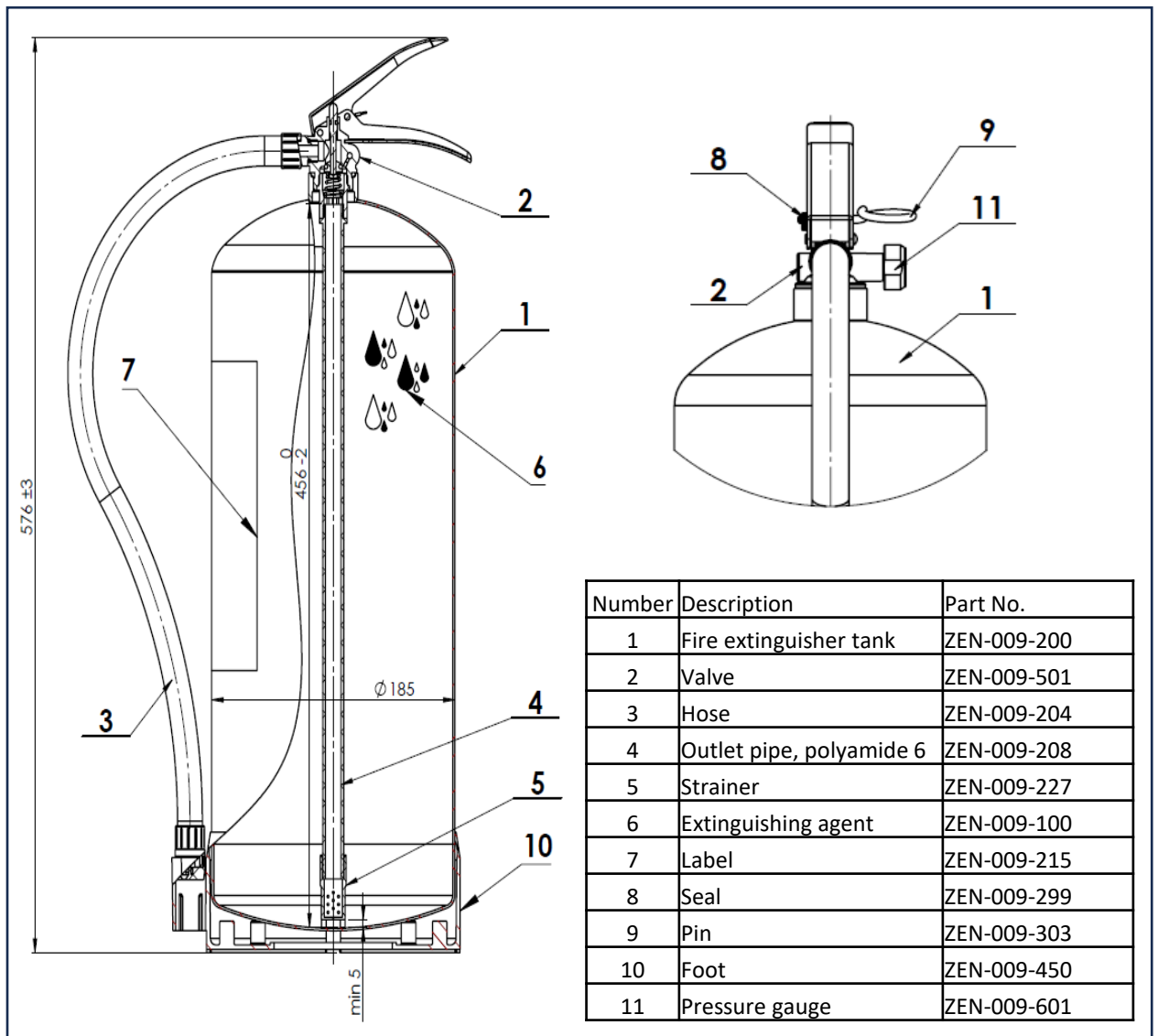

Number	Description	Part No.
1	Fire extinguisher tank	ZEN-009-200
2	Valve	ZEN-009-501
3	Hose	ZEN-009-204
4	Outlet pipe, polyamide 6	ZEN-009-208
5	Strainer	ZEN-009-227
6	Extinguishing agent	ZEN-009-100
7	Label	ZEN-009-215
8	Seal	ZEN-009-299
9	Pin	ZEN-009-303
10	Foot	ZEN-009-450
11	Pressure gauge	ZEN-009-601